



E HAWK Electric Zone Kenya

D1



Introduction

Call our rep today for quote also ask us about wholesale opportunity sell this e moto in your store. 072 98 05201



Value Points

Appearance



Capacity



Endurance



Powerful



Accessories



Safe



Strong



Steady



Comfortable



Removable





APPEARANCE

Minimalist design concept

Simple streamline U-shaped line design

Integration with carrying function

**Creating multi-purpose e-motorcycle with
good appearance**





CAPACITY

200KG

· **Three-stage integrated loading platform**

Low center of gravity, easy to operate, greater convenience and stronger capacity





ENDURANCE

60V40Ah lithium battery- ultra-long standby time

Extremely long battery endurance up to 100KM





POWERFUL

**2000W Motor to guarantee
no fear of steep slopes**

Maximum power 3000W

Peak torque up to 120N.m

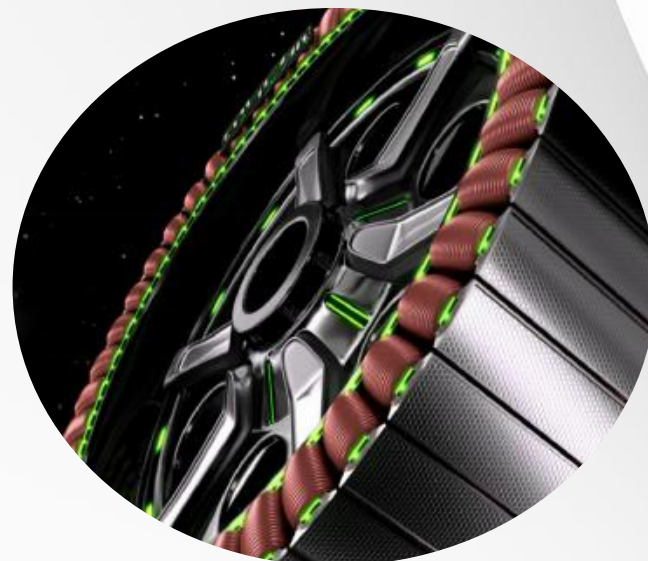



Accessories

- **Strong front&rear carriers**
- **Hard foam food boxes**
- **Special side wheels for heavy goods**





SAFE

**Front and rear disc brakes with CBS
effectively shorten the braking distance
and ensure riding safety**





STRONG

Thickened steel pipes frame



**The frame passes 300,000 times fatigue failure
vibration test with 200KG load**

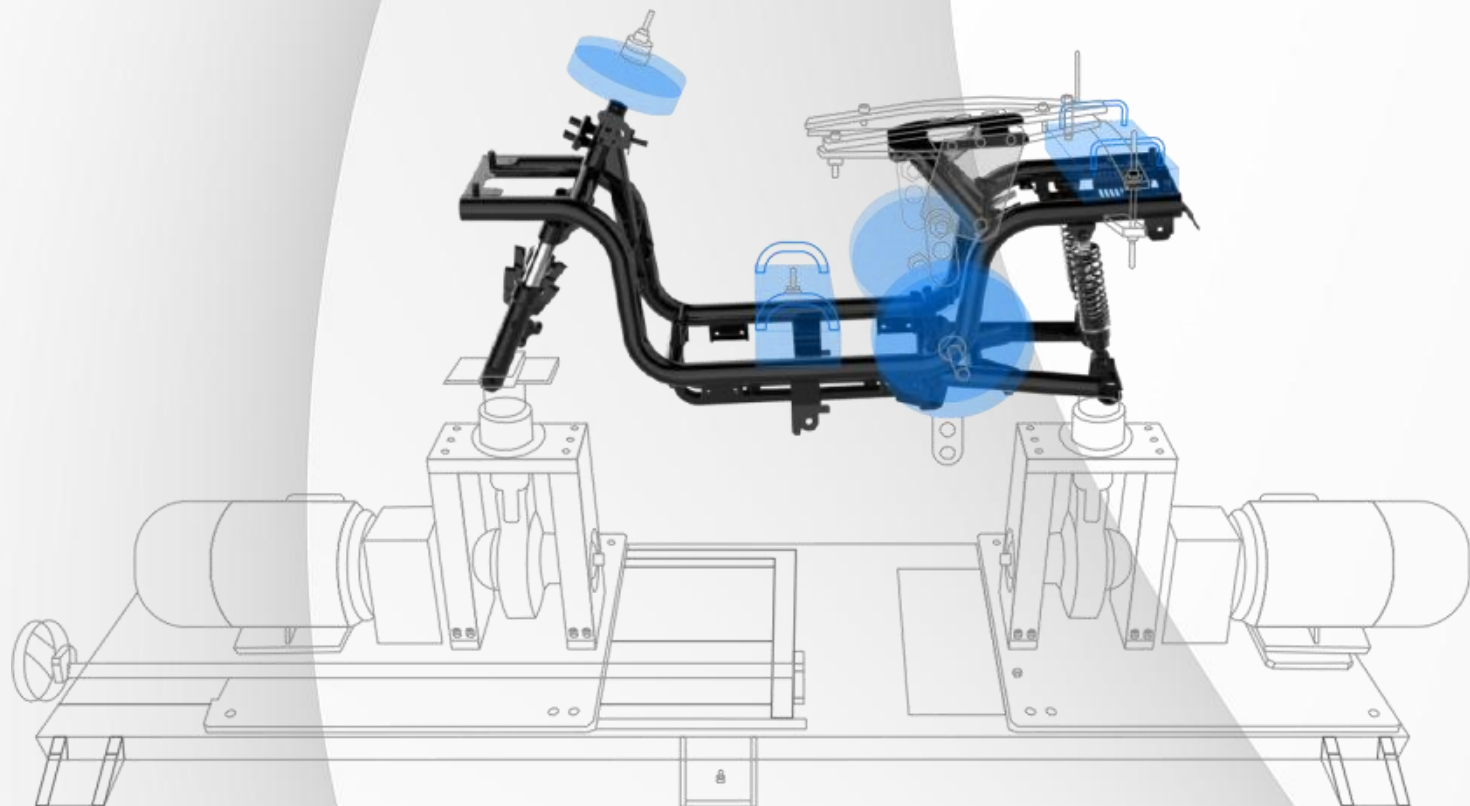



STEADY

- **Front and rear hydraulic shock absorbers**
Bold and reinforced shock absorbers
Precise adjustment, comfortable riding
No fear of bumps





Comfortable



- **Widened and thickened large saddle front&rear**
- **Thickened backrest**
- **High-density polyurethane foaming process**



REMOVABLE

Battery easily taken out

Integrated pedal battery box system

Two-step quick pick-and-place battery





MORE FUNCTIONS

**A series of user-friendly and convenient designs
have greatly enhance the human-vehicle
interaction experience**

**Mobile phone USB charging
port
and mini storage box**



**Convenient charging port
and battery lock**



Convenient hook





Customizable exquisite colors

COLORFUL



○ Green



● Red



● Scuba blue



● Blue



Parameters

L*W*H:1780×780×1140mm

Motor: 60V2000W

Display:LED with App

wheelbase:1300mm

Max Speed :70km/h

Battery:60V40Ah Lithium

Range per charge:100 km laboratory test data

Max Load: 300 kg

Tire Size <Front / Rear>: 90/90-12 tubless

Brake <Front / Rear>: Disc brake / Disc brake

